



# SK3"P

## 3" Pneumatic Emergency Bottom Valve

### DESIGN CHARACTERISTICS

Ease of maintenance, simplicity of design and durability have helped to make this valve design the first choice of all tank truck manufacturers who require a tough, reliable, pneumatically operated valve in the 3" class.

- **High flow** low pressure drop design for increased discharge rates,
- **Robust construction** of the sell made of aluminium alloy tested for sell strength at 25bar.
- **Conforms** to the European Standard EN13308:2002 and EN16257:2012
- **Viton seals** are standard for problem free service with high octane unleaded petrol and additives.
- **Shear Groove** for increased safety.
- **Easily removable** bonnet assembly without removing the valve for easy maintenance.
- **Easy service**, air cylinder design allows replacement without removing the valve from the tank.

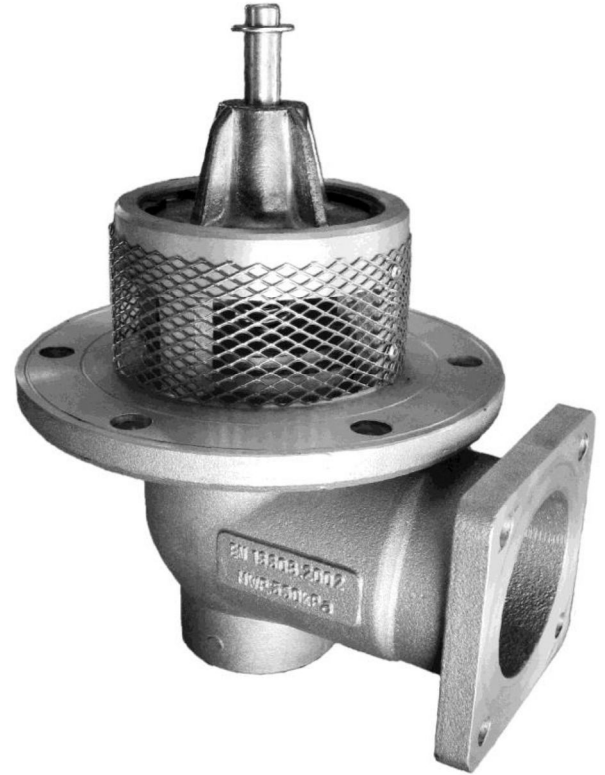

Overall Dimensions

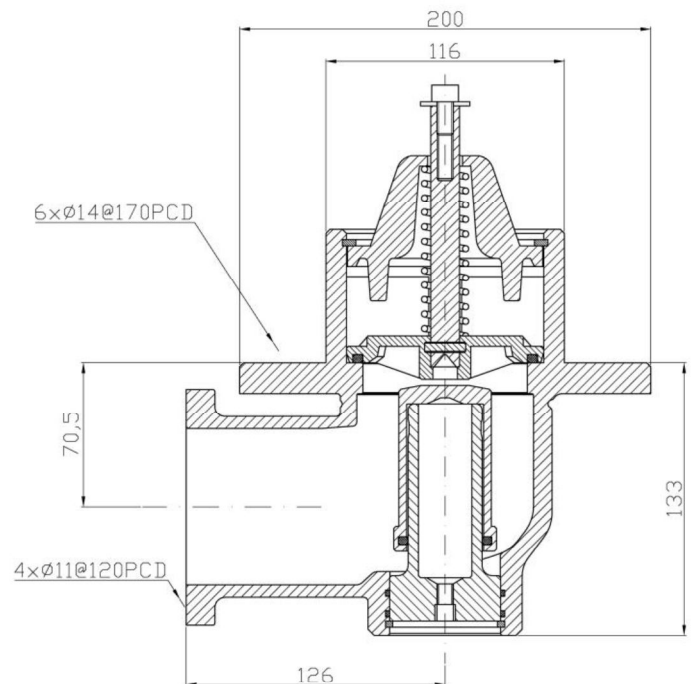

### TECHNICAL DATA

MWP : 500 kPa  
Valve Weight : 3.8 kg  
Test Pressure : 775 kPa